

XPRESS II

DESIGN AND PLANNING GUIDE



Inclined platform lift for straight stairways

Please note:

Dimensions provided in this Guide are for **REFERENCE ONLY** and should not be used for site preparation or construction.

Xpress II

Table of Contents

| | |
|--|-----------|
| What is an Inclined Platform Lift? | 3 |
| Finishes | 4 |
| How it Works | 5 |
| Component Identification | 6 |
| Standard Platform Safety Features | 7 |
| Optional Platform Features | 8 |
| Drive System | 9 |
| Guide Rails | 9 |
| Call Stations | 9 |
| Call Station Mounting Options | 10 |
| Outdoor Applications | 10 |
| Additional Safety Options | 11 |
| Platform Projection & Rail Extensions | 12 |
| Attachment Methods | 13 |
| Pedestrian Handrail | 14 |
| Wall Height Requirement for Direct Mounting | 16 |
| Xpress II Loading Diagram | 17 |
| Typical Wiring Layout | 18 |
| Technical Reference of Standard Features | 19 |

What is an Inclined Platform Lift?

An inclined platform lift easily transports a passenger in a wheelchair or someone who has difficulty with stairs. The lift can be operated independently or by an attendant with an attendant remote control (optional item). Compatible for indoor and outdoor applications, the Garaventa Inclined Platform Lift is a versatile, attractive and cost-effective accessibility solution.

Why an Inclined Platform Lift?

No Building Renovations (Modifications)

Inclined platform lifts fit easily into most stairways and do not require specially constructed hoistways.

Preserve Heritage Buildings

Flexibility in design enables Garaventa's designers to adapt an inclined platform lift to virtually any building site with very little or no structural modifications. The availability of many colors and finishes ensures the lift will blend with its environment and preserve the look of a heritage building.

Save Valuable Floor Space

Floor space within a business building or a school is valuable commodity. Garaventa Lift Inclined platform lifts utilize very little of this premium space.

Meet ADA Requirements

Garaventa inclined platform lifts are approved in the ADA Accessibility Guidelines as a means to provide public building access when licensed for independent operation. They may also be used as an accessible means of egress when equipped with an auxiliary standby power system.

Design Assistance

With over 25 years of experience, Garaventa Lift is willing and able to overcome almost any design challenge you face. Please call our Design Hot Line or email us with your accessibility challenge.

1-800-663-6556 or 1+604-594-0422
Email: productinfo@garaventlift.com

Finishes

Standard Color

The Xpress II rails and loading ramps are made of champagne anodized aluminum. The non-aluminum components of the lift are finished in a durable polyester powder paint coating that is electro statically applied and baked at 210° C (410°F). Garaventa Lift's standard color, Satin Grey (finetextured), complements a variety of modern and traditional decors (color samples are available upon request). The conveyance cover and upper rail end caps are made of beige colored high quality ABS/PVC.

Custom Colors (Optional)

Garaventa Lift also offers a choice of colors from the internationally accepted RAL color charts (color samples are available upon request).

The following list of items will be powder coated to the specified color when a custom color is ordered (for some of these items - see picture below right):

- (A) upper and lower rails
- (B) pedestrian handrail
- (C) platform grab rail
- (D) curved arms
- (E) sensing plate, call stations, towers (if ordered)

Optional paint finishes include brass and stainless effects.



Standard Color



Custom Color Example

How It Works

The platform of the Xpress II travels along two custom designed extruded aluminum rails that can be mounted either directly to the wall or to support posts (towers). The upper rail houses a gear rack and a traveling cable while the lower rail provides lateral support. The platform is propelled by means of a carriage mounted rack and pinion drive system.

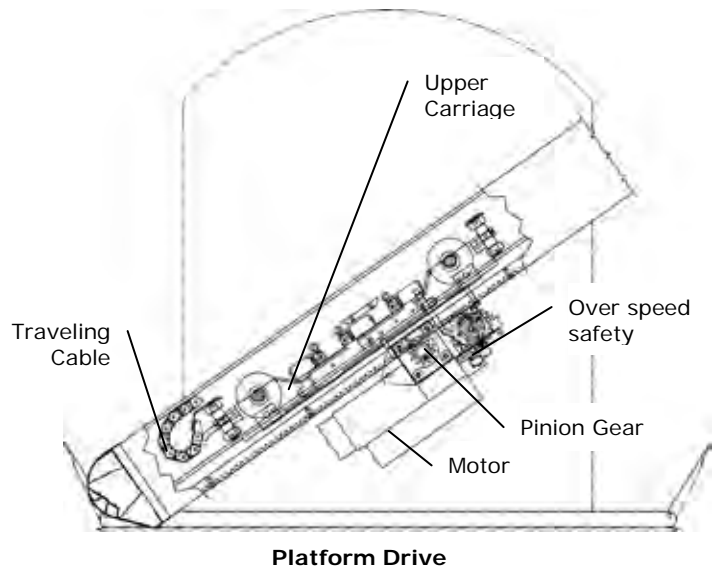

Over speed Safety

The Over speed Safety located in the upper carriage on the platform, consists of a mechanical pawl and electrical cutout switch. In the unlikely event that the lift should descend too quickly, both the mechanical and electrical safety will activate simultaneously and stop the platform from moving.

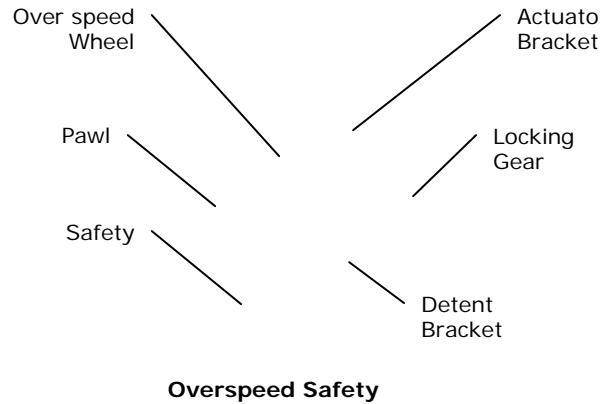

Component Identification

The main components of the Xpress II are:

- Hanger inc Drive System
- Platform
- Extruded Aluminum Guide Rails
- Call Stations

Platform

Platform Sizes

The platform is available in three standard sizes, with a rated load of 225 kg. (495lbs.).

- 800 x 1250mm (31 1/2" x 49 1/4")
- 800 x 1000mm (31 1/2" x 39 3/8")
- 750 x 900mm (29 1/2" x 35 1/2")

For narrower staircases 2 optional platforms are available:

- 725 x 1000mm (28 1/2" x 39 3/8")
- 675 x 1000mm (26 1/2" x 39 3/8")

*Curved safety arms not available on 675 x 1000mm platform, powered straight arms can be provided.

Platform Controls

The durable and vandal resistant platform control panel is mounted to the platform control panel. The standard platform controls consist of two large illuminated constant pressure Directional Buttons for independent operation and an Emergency Stop Button (with illumination optional).

Attendant Remote Control Unit

The platform can be equipped with an optional **Attendant Remote Control** that overrides the **Directional Buttons** during attendant operation. The remote control unit can be removed when not required.

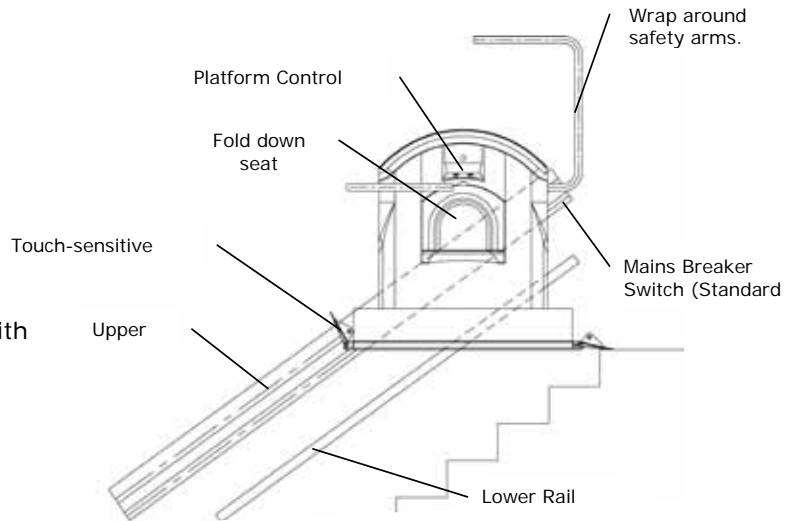

Direct Mount Configuration System

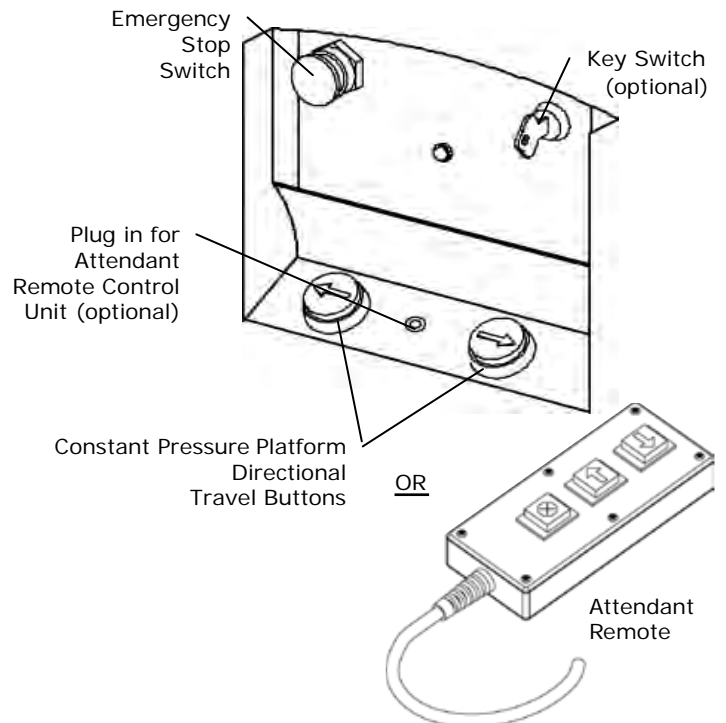

Standard Platform Safety Features

Emergency Stop Button

Located on the platform control panel, this large red button is used to stop the lift in an emergency (an illuminated stop button with alarm is also available).

Safety Sensing

The platform is equipped with safety sensors listed below. These sensors will automatically stop the lift when activated by 1.8 kg (4 lbs.) of pressure. The platform can then be backed away from the obstruction allowing the object to be removed.

i) Leading Ramp Sensor

When the platform is called to or from the landing area in the folded up position the leading ramp is sensitive to obstructions.

ii) Under Platform Sensing Plate

The under platform sensing plate detects obstacles underneath the platform.

ii) Bi-Directional Ramp Sensing

The ramps are designed to be obstruction sensitive in the direction of travel on the outside of the ramps as well as from within the platform. The internal ramp sensor prevents a wheelchair from being off-center on the platform deck.

Platform Grab Rail

This safety feature increases the ease with which passengers may load and unload from the platform.

Emergency Fold

In an emergency the platform is able to be manually folded and will held in the folded position with the supplied durable nylon strap.

Passenger Restraining Arms

Fully automatic restraining arms are standard on the Xpress II. Most safety codes require inclined lifts to be equipped with passenger restraining arms.

Hour Counter

The hour counter enables the owner to determine the amount of time the Xpress II inclined platform lift has been used. This is a helpful tool for determining preventive maintenance intervals.

Keyless Platform

The platform comes standard without a key switch.

Manual Emergency Lowering

Included with every lift the lowering hand wheel enables an attendant to lower the platform in case of an emergency. (The hand wheel is not user operable.)

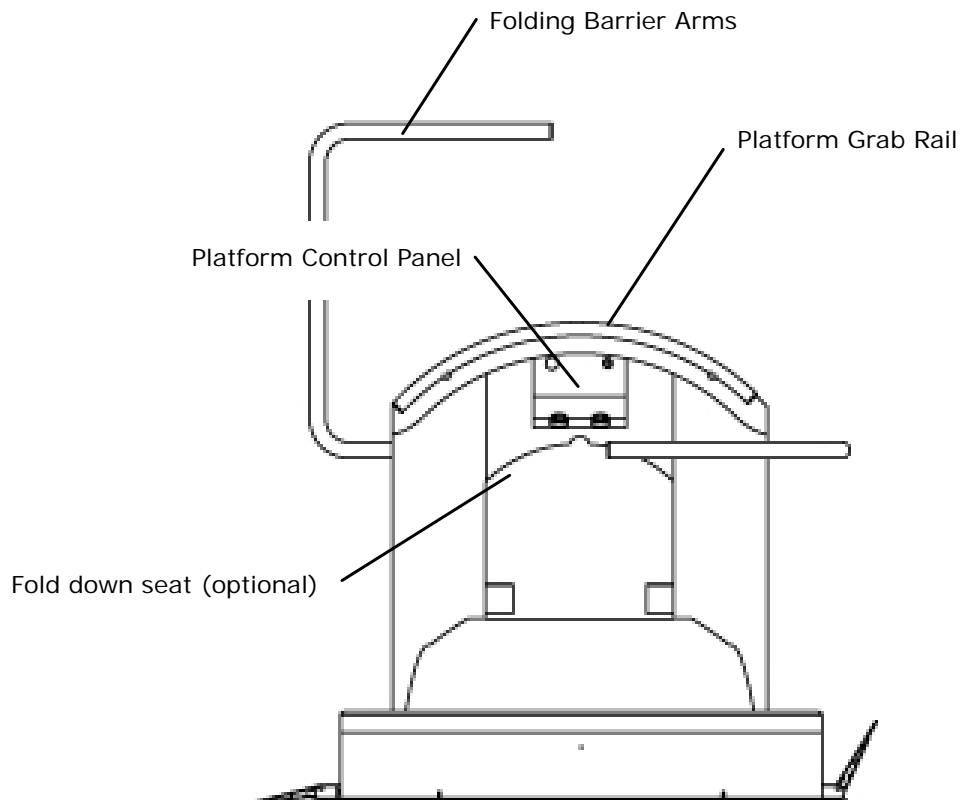

Optional Platform Features

Folding Seat Assembly

Designed for use by semi-ambulatory passengers, the folding seat is equipped with a safety belt.

Side Load

Designed for confined lower landing areas. The side ramp opens simultaneously with the end ramp. This allows the passenger to wheel onto the platform diagonally offering easier access.

Auto Fold

This feature will allow the lift to automatically fold, if left unattended for a period of time at a landing. This ensures the stairway remains clear in the event someone forgets to fold the lift. The time delay is adjustable in the field by an authorized Garaventa technician.

Emergency Battery Lowering

During a power outage this feature allows the lift to be lowered to the bottom landing. The Battery Lowering System is located on the lift inside the platform.

Illuminated Emergency Stop Button and Alarm

The emergency stop button can be illuminated and activate an onboard alarm when required by code.

Change of Direction Time Delay

In applications where a time delay is required when changing directions, either by code or user preference, the lift can be equipped with a variable time delay.

Keyed platform

Protects the lift from unauthorized use.

Platform lock

This feature locks the platform and protects the unit from vandalism.

***Note:** In some areas certain optional features are either not permitted or mandatory depending on local codes. Please consult your local Garaventa representative for clarification.

Drive System

The carriage mounted drive system consists of a 3/4 H.P. motor, a gearbox, pinion gear and flexible traveling cable.

Mains Power

The mains power requirement is 208 to 240VAC, single phase, on a dedicated circuit (North America: 20 ampere, Europe: 16 ampere). A lockable supplementary mains disconnect switch is mounted at the end of the upper rail.

Guide Rails

Two extruded aluminum extrusions make up the guide rail assembly. The upper rail houses the rack that the platform's pinion gear utilizes for travel. The platform is mechanically attached to this upper rail. The lower rail is used as a guide track for the rollers of the lower carriage assembly. The upper and lower rail heights are based on the stair angle and the platform size. For more information on rail heights see page 16.

Call Stations

Each landing is equipped with a call station. The call station enables the user to unfold the platform with a touch of a button. If the platform is not at their landing the user simply presses the directional button to bring the platform to their landing.

Optional Call Station Features

To meet customer or code requirements an optional Emergency Stop Button and an Attendant Call Switch can be added to the call station.

Keyless Operation

This feature allows the user to operate the lift without a key. The standard key switches on the call stations are removed and plugged.

Call with Platform Open (Confirm with local code authorities -adjustable in field)

This option is typically used when the lift can not be called from a call station to overhead clearance issues. With this option, the lift travels with the arms in the horizontal position and platform folded down only. This option which is adjustable in the field can be enabled by a jumper setting on site. An appropriate label (#37033) has to be ordered, which replaces the regular "operating instructions" manual.

Remote Platform Fold

This feature allows the platform to be folded up from any call station should the platform be left unfolded at a landing.

Call Station Mounting Options

The call stations can be mounted on the wall (surface or flush mounted). Flush mount call stations can be pre-wired during the construction or building renovations resulting in a cleaner appearance with no surface wiring. The optional flush call station box dimensions are:

Length: 185 mm (7 1/4")

Width: 115 mm (4 1/2")

Depth: 52 mm (2")

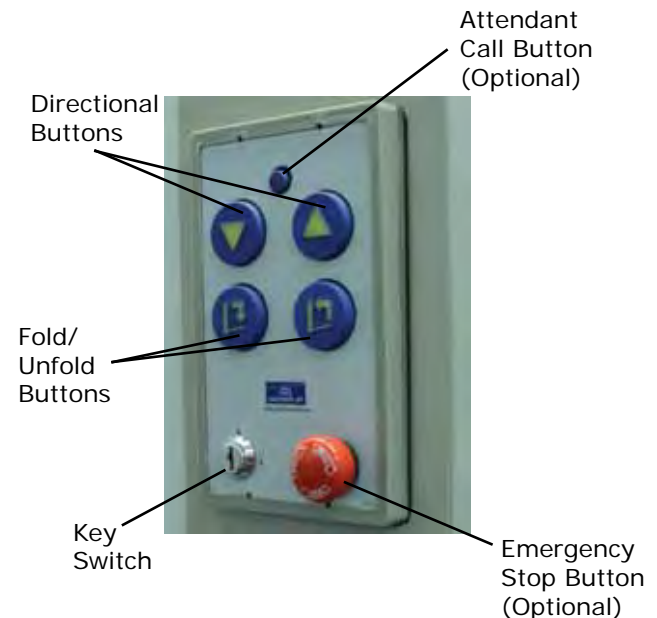

Outdoor Applications

Because most components of the Xpress II are made of anodized aluminum they are already prepared for outdoor use. Any components that are not made of aluminum are zinc plated. If the Xpress II is to be used outdoors or in an extreme environment (e.g. near swimming pools, hot tubs, chemicals, etc.) it is necessary to use stainless steel fasteners and support towers (if required, see Attachment Methods). An outdoor platform cover can be purchased (optional) to assist in protection in severe weather areas.

Additional Safety Options

The Xpress II can be equipped with a number of additional safety features:



Audio Visual Alert

When the lift is in use, a wall mounted strobe light and audible chime cautions pedestrians in the vicinity that the lift is in operation (as shown above). The volume of the audible chime can be adjusted on site.

Fire Alarm Integration (Fire Service)

Designed to interface with a building's fire safety system and interrupt power to the lift when the fire alarm sounds. This ensures the lift will not obstruct stairway traffic during evacuation. If the lift is in use when the alarm sounds, the lift will only allow the passenger to use the constant pressure direction button to travel to the designated landing with the emergency exit.



Attendant Remote Control

The platform can be equipped with an optional Attendant Remote Control that overrides the Directional Buttons during attendant operation. The platform remote control unit can be removed when not required.

Auxiliary Power (Battery not included)

This feature (as shown above) ensures that the lift continues to operate during a power outage. The self-contained battery unit can be located up to 4.5 meters (15') away from the drive system and will power the lift up to one hour at full capacity.

Box Size:

597 mm (23 1/2") H x 444 mm (17 1/2") W x 192 mm (7 5/8") D

Minimum Site Dimension Requirements

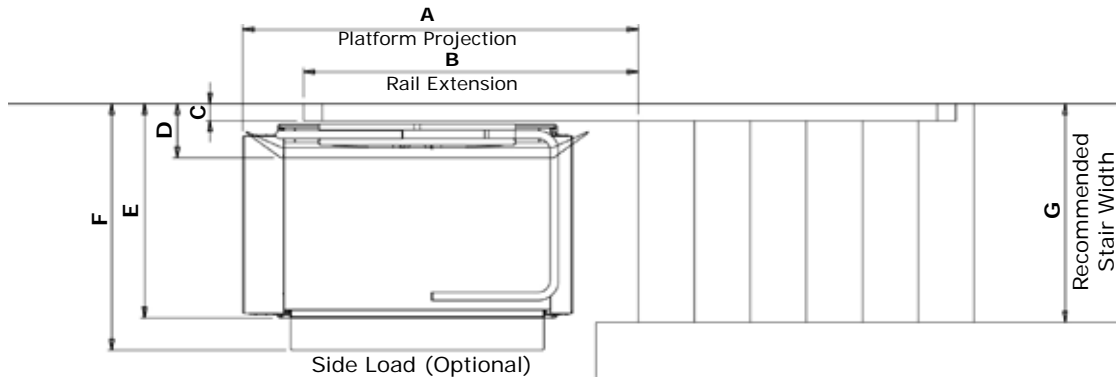

Platform Projection and Rail Extensions

| Stair Angle | 10° | 15° | 20° | 25° | 30° | 35° | 40° | 45° |
|--|-----------------|----------------|----------------|----------------|----------------|----------------|----------------|----------------|
| Dimension A - Platform Projection | | | | | | | | |
| 800 x 1250mm Platform (31 1/2" x 49 1/4") | 2863 112 3/4 | 2399 94 1/2 | 2163 85 1/4 | 2021 79 5/8 | 1924 75 7/8 | 1854 73 | 1799 70 7/8 | 1756 69 1/4 |
| 800 x 1000mm Platform (31 1/2" x 39 3/8") | 2618 103 1/8 | 2154 84 3/4 | 1918 75 1/2 | 1776 69 7/8 | 1679 66 1/8 | 1609 63 3/8 | 1554 61 1/8 | 1511 59 1/2 |
| 750 x 900mm Platform (29 1/2" x 35 1/2") | 2502 98 1/2 | 2052 80 3/4 | 1818 71 5/8 | 1676 66 | 1579 62 1/4 | 1509 59 1/2 | 1454 57 1/4 | 1411 55 5/8 |
| Dimension B - Rail Extension | | | | | | | | |
| 800 x 1250mm Platform (31 1/2" x 49 1/4") | 2553 101 1/8 | 2101 83 3/8 | 1870 74 1/4 | 1729 68 3/4 | 1629 64 3/4 | 1551 61 3/4 | 1485 59 1/8 | 1426 56 3/4 |
| 800 x 1000mm Platform (31 1/2" x 39 3/8") | 2430 95 5/8 | 1976 77 3/4 | 1745 68 3/4 | 1604 63 1/8 | 1504 59 1/4 | 1426 56 1/8 | 1360 53 1/2 | 1301 51 1/4 |
| 750 x 900mm Platform (29 1/2" x 35 1/2") | 2365 93 1/8 | 1924 75 3/4 | 1695 66 3/4 | 1554 61 1/4 | 1454 57 1/4 | 1376 54 1/4 | 1310 51 5/8 | 1251 49 1/4 |

Note: These dimensions are based on a first riser height of **190mm (7 1/2")**. The platform projection and rail extension will be shorter than indicated for shallow stairs below 25° as they may have shorter first risers, please consult Garaventa Lift.

Stair Width Clearance for Different Attachment Methods

| Clearance Width Dimensions | C Rail Protrusion | | D Platform Folded | | E Platform Unfolded | | F Side Load Ramp | | G Stair Width | |
|---|----------------------|-------|----------------------|--------|------------------------|--------|---------------------|--------|------------------|--------|
| | mm | in | mm | in | mm | in | mm | in | mm | in |
| 800 x 1250 mm (31 1/2" x 49 1/4") & 800x 1000 mm (31 1/2" x 39 3/8") Platforms | | | | | | | | | | |
| Direct Mount Towers | 81 | 3 1/4 | 260 | 10 1/4 | 1020 | 40 1/8 | 1175 | 46 1/4 | 1040 | 41 |
| | 145 | 5 3/4 | 325 | 12 3/4 | 1084 | 42 5/8 | 1239 | 48 3/4 | 1104 | 43 1/2 |
| *750 x 900 mm (29 1/2" x 35 1/2") Platform | | | | | | | | | | |
| Direct Mount Towers | 81 | 3 1/4 | 299 | 11 3/4 | 927 | 36 1/2 | N/A | N/A | 947 | 37 1/4 |
| | 145 | 5 3/4 | 364 | 14 3/8 | 992 | 39 | N/A | N/A | 1012 | 39 7/8 |
| 725 x 1000 mm (28 1/2" x 39 3/8") Platform | | | | | | | | | | |
| Direct Mount Towers | 81 | 3 1/4 | 260 | 10 1/4 | 945 | 37 1/4 | 1100 | 43 1/4 | 965 | 38 |
| | 145 | 5 3/4 | 325 | 12 3/4 | 1009 | 39 3/4 | 1164 | 45 7/8 | 1029 | 40 1/2 |
| 675 x 1000 mm (26 1/2" x 39 3/8") Platform | | | | | | | | | | |
| Direct Mount Towers | 81 | 3 1/4 | 260 | 10 1/4 | 895 | 35 1/4 | 1050 | 41 3/8 | 915 | 36 |
| | 145 | 5 3/4 | 325 | 12 3/4 | 959 | 37 3/4 | 1114 | 43 7/8 | 979 | 38 1/2 |

Attachment Methods

The extruded aluminum guide and support rails can be directly mounted to the wall or attached to steel support towers. There are various attachment methods used to support the Xpress II.

Direct Mount Anchored to Solid Walls

- Solid concrete (152mm (6") thick minimum)
- Concrete block (203mm (8") minimum without reinforcement or 152mm (6") minimum with reinforcement)
- Wood support posts located in wall (4" x 6" minimum). Locations determined by Garaventa.
- Steel support posts located in the wall. 76mm x 76mm x 6mm wall / (3" x 3" x 1/4") minimum. Locations determined by Garaventa.

Direct Mount Anchored to Wood Stud or Thin Block Walls

The upper rail must be attached to a 2" x 8" board that is secured to the wall. For the lower rail, a 2" x 4" board can be used. Each board must be fastened into every available wall stud with minimum two screw fasteners.

Note: Not Suitable for Steel Stud Applications.

Freestanding Support Towers

Required where no support walls exist, or when the lift must be located away from a wall structure.

- Solid concrete stairs/landings
- Wood stairs/landings over 76.2mm (3") thick
- Concrete steel pan treads (towers must be secured back to the stringer with brackets for extra support)

Open Balustrade (Towers in the core)

In situations where the stairs cannot support freestanding towers and where direct mounting is not feasible, it may be possible to install support towers in the open core. This may also be a solution where there is insufficient clearance with towers on the treads. The towers are fastened to the floor and secured to walls or stringers.

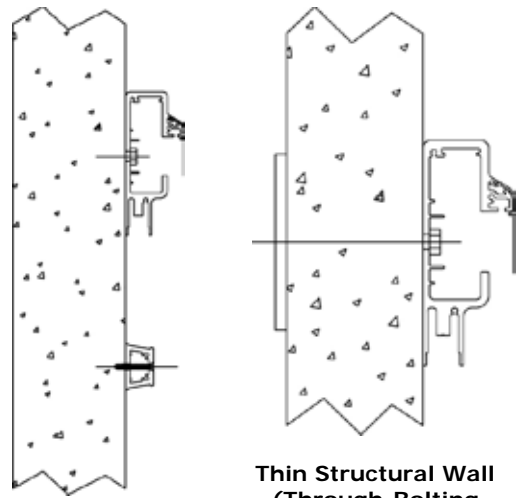

Direct Mount to Wall

Thin Structural Wall
(Through-Bolting may be applied)

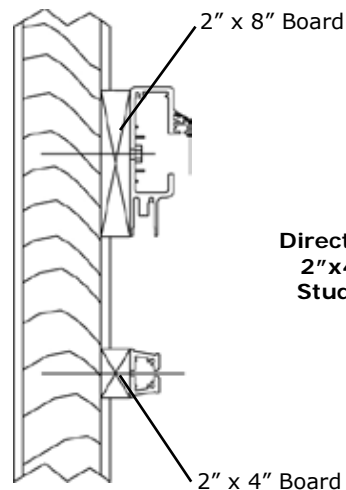

Direct Mount to 2"x8" and
2"x4" Boards on Wood
Stud or Thin Block Wall

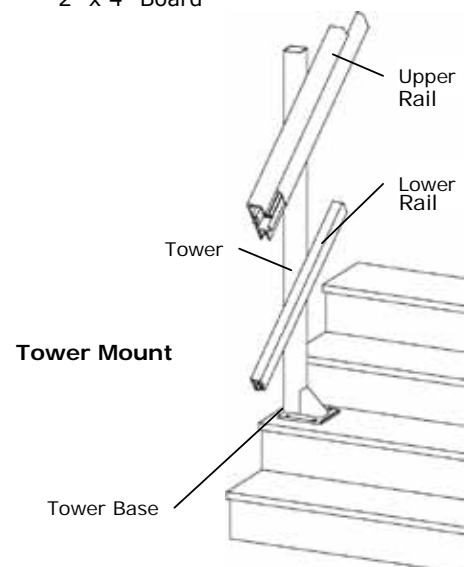

Tower Mount

Pedestrian Handrail

A pedestrian handrail can be mounted to the top of the upper rail section to assist pedestrians using the stairs. *(Due to platform interference during travel, the handrail may not fully comply with building code requirements.)*

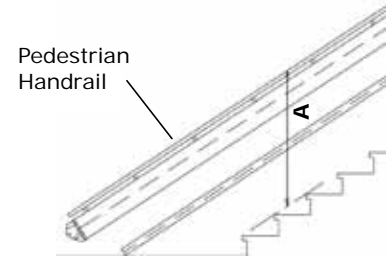

Pedestrian Handrail Heights

| Stair Angle | 10° | 15° | 20° | 25° | 30° | 35° | 40° | 45° |
|--|---------------|---------------|---------------|----------------|----------------|----------------|----------------|----------------|
| Dimension A - Handrail Height | | | | | | | | |
| 800 x 1250mm Platform (31 1/2" x 49 1/4") | 800 31 1/2 | 866 34 1/8 | 941 37 | 1020 40 1/8 | 1112 43 3/4 | 1215 47 7/8 | 1335 52 1/2 | 1477 58 1/8 |
| 800 x 1000mm Platform (31 1/2" x 39 3/8") | 778 30 5/8 | 833 32 3/4 | 895 35 1/4 | 962 37 7/8 | 1039 40 7/8 | 1127 44 3/8 | 1230 48 3/8 | 1352 53 1/4 |
| 750 x 900mm Platform (29 1/2" x 35 1/2") | 770 30 3/8 | 820 32 3/8 | 876 34 1/2 | 939 37 | 1010 39 3/4 | 1092 43 | 1188 46 3/4 | 1302 51 1/4 |

Overhead Clearances Required

| Stair Angle | 10° | 15° | 20° | 25° | 30° | 35° | 40° | 45° |
|---|----------------|----------------|----------------|----------------|----------------|-----------------|-----------------|-----------------|
| Dimension B - Overhead Clearance Platform Folded Up (No Arms) | | | | | | | | |
| 800 x 1250mm Platform (31 1/2" x 49 1/4") | 1427 56 1/8 | 1546 60 7/8 | 1674 65 7/8 | 1811 71 1/4 | 1963 77 1/4 | 2134 84 | 2329 91 3/4 | 2558 100 3/4 |
| 800 x 1000mm Platform (31 1/2" x 39 3/8") | 1386 54 5/8 | 1483 58 3/8 | 1588 62 1/2 | 1701 67 | 1827 71 7/8 | 1969 77 1/2 | 2131 83 7/8 | 2323 91 1/2 |
| 750 x 900mm Platform (29 1/2" x 35 1/2") | 1317 51 7/8 | 1374 54 1/8 | 1440 56 3/4 | 1516 59 3/4 | 1606 63 1/4 | 1735 68 3/8 | 1896 74 5/8 | 2083 82 |
| Dimension C - Overhead Clearance Platform Folded Up (With Arms) | | | | | | | | |
| 800 x 1250mm Platform (31 1/2" x 49 1/4") | 1917 75 1/2 | 2031 80 | 2152 84 3/4 | 2281 89 3/4 | 2426 95 1/2 | 2584 101 3/4 | 2765 108 7/8 | 2977 117 1/4 |
| 800 x 1000mm Platform (31 1/2" x 39 3/8") | 1876 73 7/8 | 1968 77 1/2 | 2066 81 3/8 | 2172 85 1/2 | 2288 90 1/8 | 2419 95 1/4 | 2568 101 1/8 | 2742 108 |
| 750 x 900mm Platform (29 1/2" x 35 1/2") | 1863 73 3/8 | 1950 76 3/4 | 2043 80 1/2 | 2145 84 1/2 | 2256 88 7/8 | 2380 93 3/4 | 2524 99 3/8 | 2691 106 |
| Dimension D - US Code for Overhead Clearance (1524mm (60") above Platform) | | | | | | | | |
| 800 x 1250mm Platform (31 1/2" x 49 1/4") | 1845 72 5/8 | 1961 77 1/4 | 2084 82 | 2215 87 1/4 | 2358 92 7/8 | 2516 99 | 2696 106 1/8 | 2904 114 3/8 |
| 800 x 1000mm Platform (31 1/2" x 39 3/8") | 1803 71 | 1898 74 3/4 | 1998 78 5/8 | 2105 82 7/8 | 2222 87 1/2 | 2351 92 1/2 | 2498 98 3/8 | 2669 105 1/8 |
| 750 x 900mm Platform (29 1/2" x 35 1/2") | 1781 70 1/8 | 1867 73 1/2 | 1958 77 1/8 | 2056 81 | 2162 85 1/8 | 2279 89 3/4 | 2413 95 | 2569 101 1/8 |
| Dimension E - Canadian Code for Overhead Clearance (1500mm (59") above Centerline of Platform) | | | | | | | | |
| 800 x 1250mm Platform (31 1/2" x 49 1/4") | 1713 67 1/2 | 1774 69 7/8 | 1838 72 3/8 | 1907 75 1/8 | 1982 78 3/8 | 2134 84 | 2329 91 3/4 | 2558 100 3/4 |
| 800 x 1000mm Platform (31 1/2" x 39 3/8") | 1691 66 5/8 | 1740 68 1/2 | 1792 70 1/2 | 1848 72 3/4 | 1909 75 1/8 | 1977 77 7/8 | 2131 83 7/8 | 2323 91 1/2 |
| 750 x 900mm Platform (29 1/2" x 35 1/2") | 1676 66 | 1723 67 7/8 | 1770 69 3/4 | 1822 71 3/4 | 1878 74 | 1940 76 3/8 | 2012 79 1/4 | 2095 82 1/2 |

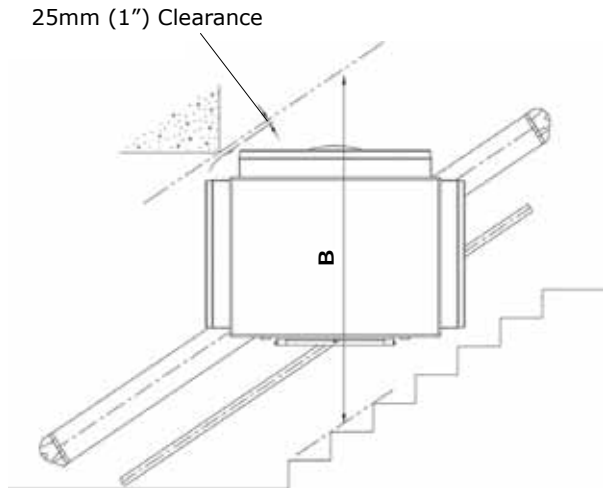

Overhead Clearances required for platform folded up (without arms)

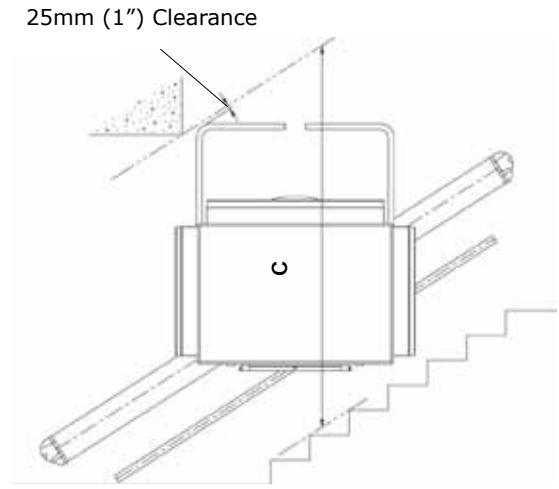

Overhead Clearances required for platform folded up (with arms)

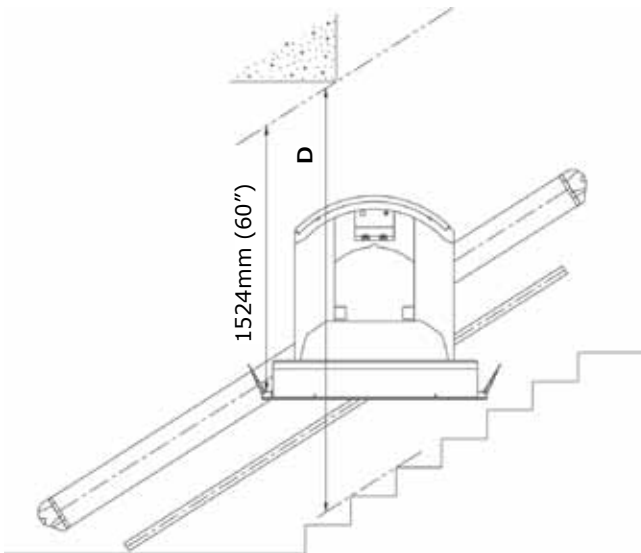

Overhead Clearances to meet US Code Requirements (ASME A18.1)

1524mm (60") overhead clearance required to any point above the platform deck. Refer to Dimension D in the Overhead Clearances chart.

Note: Consult the local Garaventa Lift representative for status for ASME A18.1 safety code requirements.

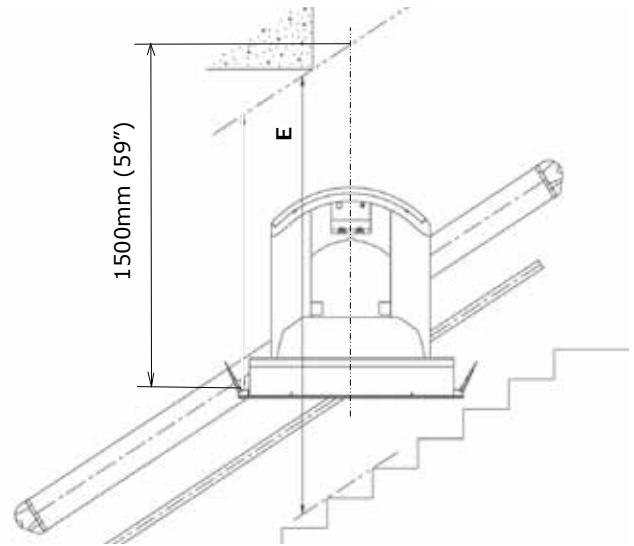

Overhead Clearances to meet Canadian Code Requirements (CSA B355-2009)

1500mm (59") overhead clearance required to centerline of the platform. Refer to Dimension E in the Overhead Clearances chart.

Wall Height Requirement for Direct Mounting

*K dimension is to top of upper rail for placement of 2"x8" (if required). True wall height is dimension K plus 35 mm (1 3/8").

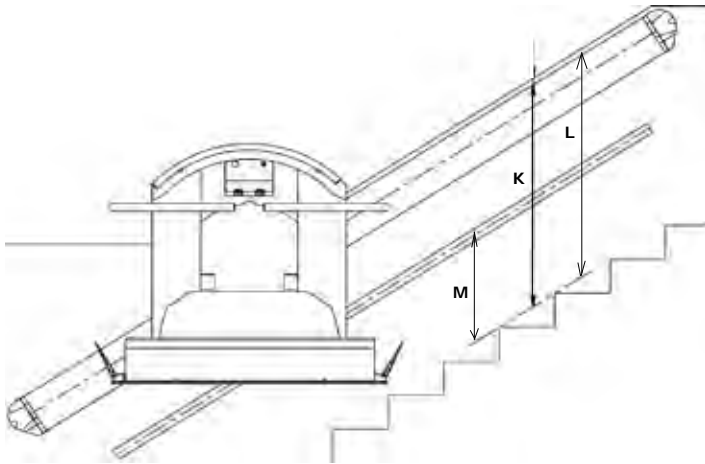

| Stair Angle | 10° | 15° | 20° | 25° | 30° | 35° | 40° | 45° |
|--|---------------|----------------|---------------|---------------|----------------|----------------|----------------|----------------|
| Dimension K - Min. Wall Height for Wall Mount | | | | | | | | |
| 800 x 1250mm Platform (31 1/2" x 49 1/4") | 762 30 | 827 32 1/2 | 900 35 3/8 | 975 38 3/8 | 1064 41 7/8 | 1162 45 3/4 | 1276 50 1/4 | 1410 55 1/2 |
| 800 x 1000mm Platform (31 1/2" x 39 3/8") | 740 29 1/8 | 794 31 1/4 | 853 33 5/8 | 918 36 1/8 | 991 339 | 1074 42 1/4 | 1171 46 1/8 | 1285 50 5/8 |
| 750 x 900mm Platform (29 1/2" x 35 1/2") | 709 28 | 1374 54 1/8 | 812 32 | 873 34 3/8 | 941 37 | 1019 40 1/8 | 1110 43 3/4 | 1217 48 |
| Dimension L - Upper Rail Height | | | | | | | | |
| 800 x 1250mm Platform (31 1/2" x 49 1/4") | 727 28 5/8 | 2031 80 | 865 34 | 940 37 | 1029 40 1/2 | 1127 44 3/8 | 1241 48 7/8 | 1375 54 1/8 |
| 800 x 1000mm Platform (31 1/2" x 39 3/8") | 705 27 3/4 | 1968 77 1/2 | 818 32 1/4 | 883 34 3/4 | 956 37 5/8 | 1039 40 7/8 | 1136 44 3/4 | 1250 49 1/4 |
| 750 x 900mm Platform (29 1/2" x 35 1/2") | 697 27 1/2 | 1950 76 3/4 | 800 31 1/2 | 860 33 7/8 | 927 36 1/2 | 1004 39 1/2 | 1094 43 1/8 | 1200 47 1/4 |
| Dimension M - Lower Rail Height | | | | | | | | |
| 800 x 1250mm Platform (31 1/2" x 49 1/4") | 245 9 5/8 | 306 12 | 372 14 5/8 | 442 17 3/8 | 520 20 1/2 | 606 23 7/8 | 705 27 3/4 | 818 32 1/4 |
| 800 x 1000mm Platform (31 1/2" x 39 3/8") | 222 8 3/4 | 273 10 3/4 | 327 12 7/8 | 384 15 1/8 | 448 17 5/8 | 518 20 3/8 | 599 23 5/8 | 693 27 1/4 |
| 750 x 900mm Platform (29 1/2" x 35 1/2") | 215 8 1/2 | 260 10 1/4 | 260 10 1/4 | 361 14 1/4 | 418 16 1/2 | 483 19 | 557 22 | 643 25 3/8 |

Xpress II Loading Diagram

- F1:** 121 kg (center of gravity of conveyance)
1179 N (265 lbf)
F2: 225 kg (max. loading capacity)
2207 N (495 lbf)
d1: 362mm (15.5")
d2: 678mm (26.7")

Moment at center of tower
 $M = \text{Force (F)} \times \text{distance (d)}$
 $M = F1 \times d1 + F2 \times d2$

Maximum Moment
 $M = 1923.1 \text{ kNmm}$
 17022.1 in.lbf

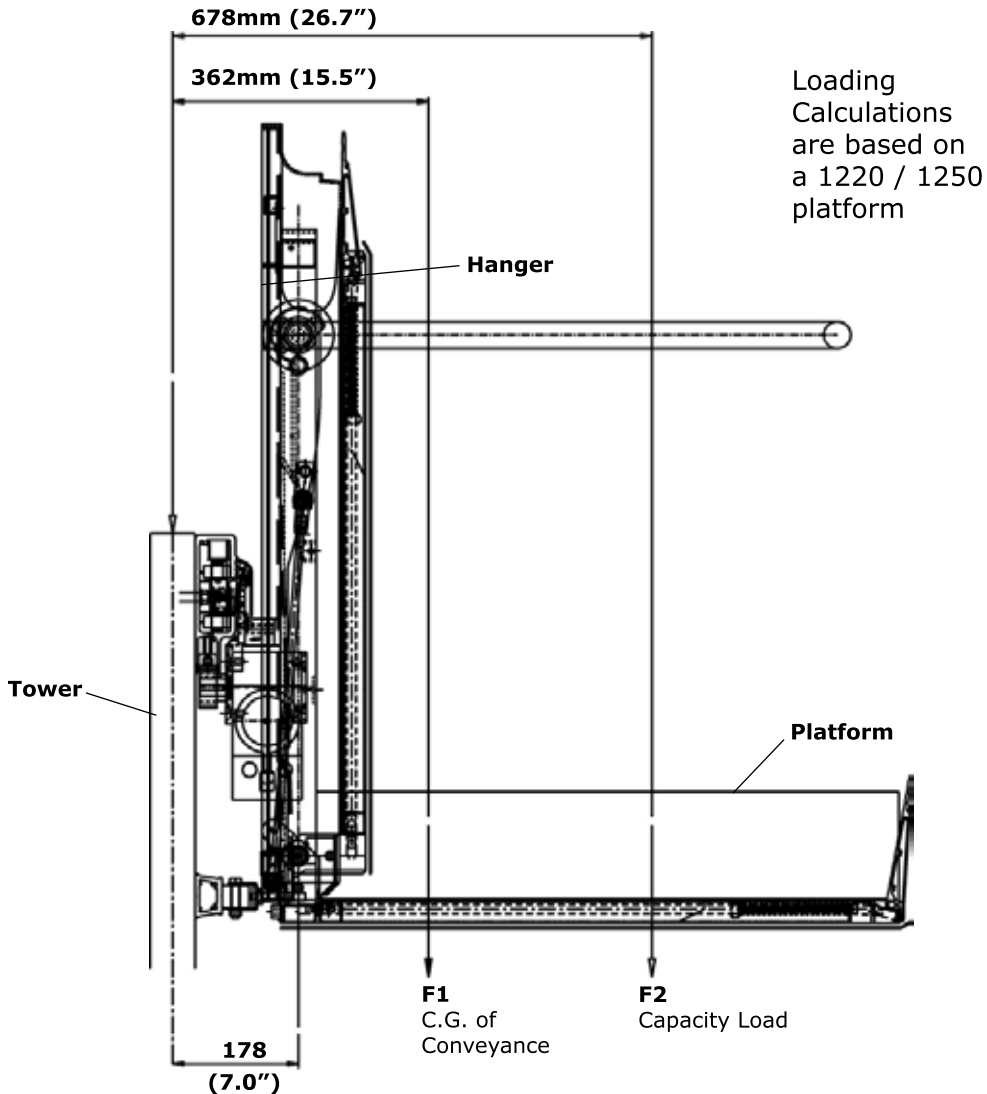

Typical Wiring Layout

Actual wiring and number of conductors may vary depending on options. Some of the options that will affect the wiring include:

- Emergency Stop switches (requires 2 additional conductors to each call station)
- Additional Audio Visual Alerts (requires 2 additional conductors to each A/V)
- Attendant Call (requires 2 additional conductors to each call station)

The following options require field wiring by others:

- Fire Service
- Auxiliary Power System
- and possibly others

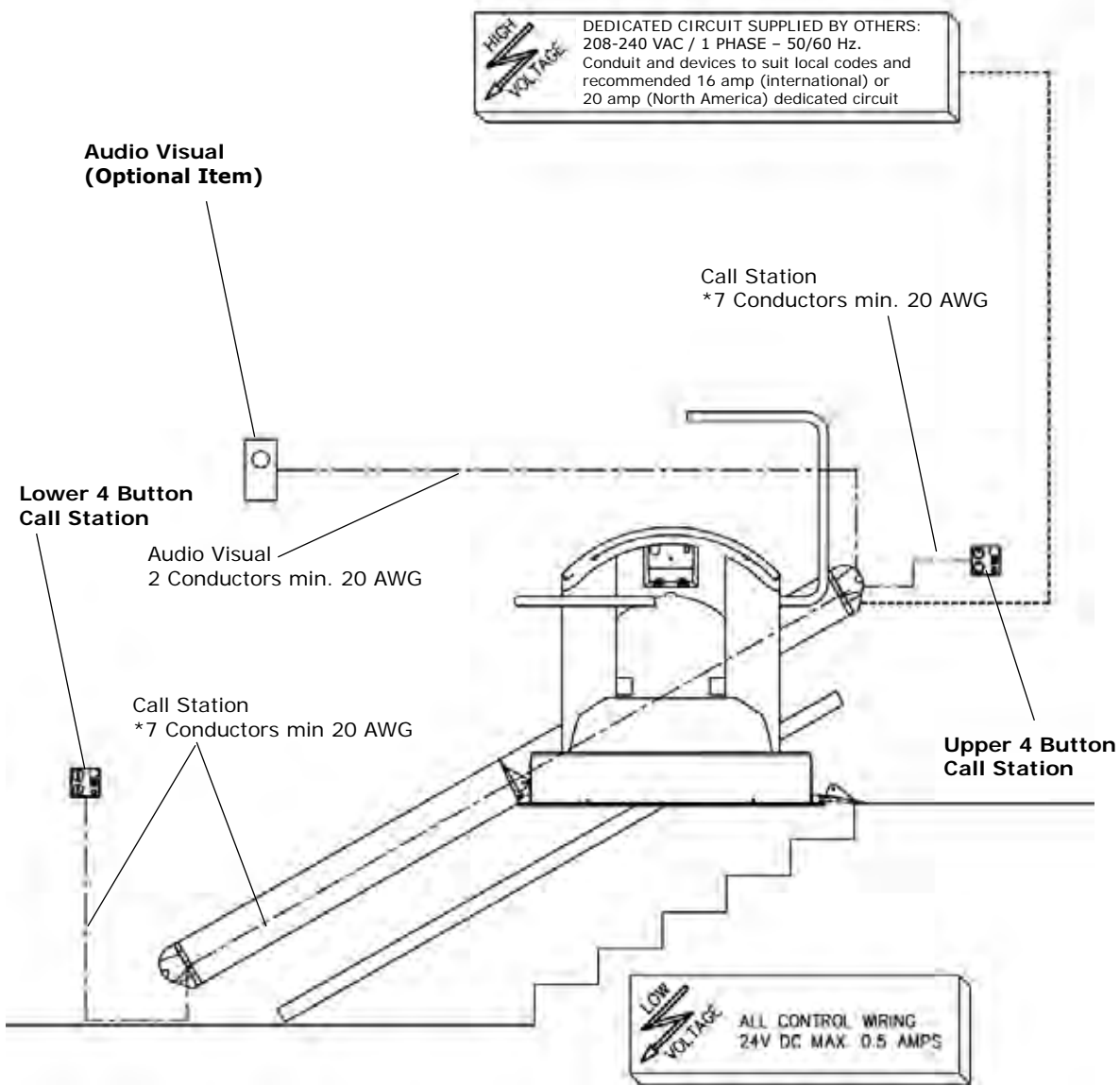

***Add 2 additional conductors each for Attendant Call (optional) & Emergency Stop Button (optional)**

Technical Reference of Standard Features

Platform Sizes:

800 x 1250mm (31 1/2" x 49 1/4") – ADA compliant
800 x 1000mm (31 1/2" x 39 3/8")
750 x 900mm (29 1/2" x 35 1/2")
725 x 1000mm (28 1/2" x 39 3/8") – optional
675 x 1000mm (26 1/2" x 39 3/8") – optional

Curved Safety Arms:

Fully automatic, 32mm (1 1/4") diameter safety arms surround the perimeter of the platform.

Rated Load:

225 kg. (495 lbs.)

Speed:

Up: 4m (13ft) per minute, Down: 5m (16ft) per minute

Operating Controls:

Call Stations (Std): Constant pressure directional buttons, one touch fold & unfold buttons, 24VDC power, and keyed operation.

Platform (Std): Constant pressure buttons, 24VDC power, Emergency Stop button (manual reset) and keyed operation.

Drive System:

Motor:
0.75 H.P. located on the platform

Power Requirements:

208-240 VAC, 50/60 HZ single phase on a dedicated circuit (North America: 20 ampere, Europe: 16 ampere).

Power Transmission:

Rack and pinion.

Emergency Use:

A hand wheel is provided. Auxiliary power system available.

Over speed Safety:

Mechanical over speed sensor and brake with electrical drive cut-out protection.

Rail System:

Champagne anodized aluminum extrusion with integrally mounted zinc plated gear.

This lift is built in accordance to ASME A18.1, CSA B44.1/ ASME A17.5, CSA B355, ASME A17.1 A variety of optional features and custom modifications are available. For more information about custom features not included in the Xpress II Design and Planning Guide and code requirements for your area consult your local Garaventa Lift representative or Garaventa Lift.



Creating An Accessible World

 Printed in Canada
15807-J-DP

© Garaventa Lift. As we are continuously improving our products, specifications outlined in this brochure are subject to change without notice.

www.garaventalift.com

Authorized Garaventa Lift Representative